

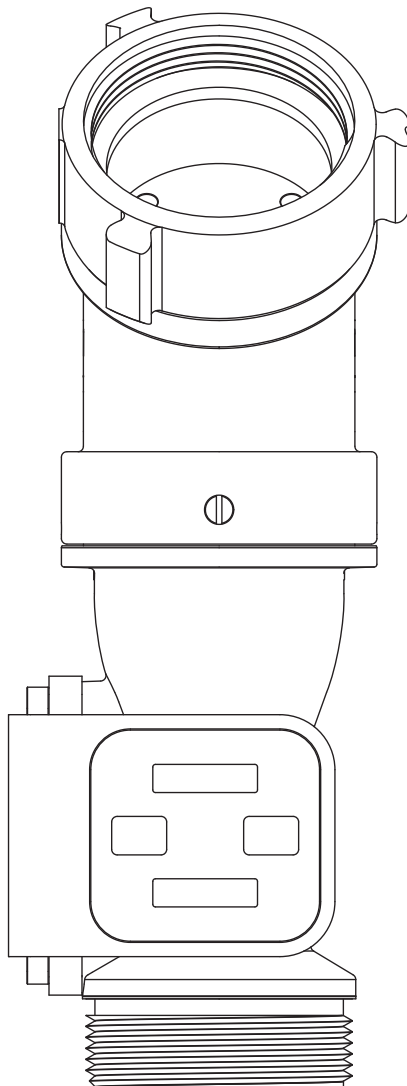

---

# PORTABLE DIGITAL STANDPIPE METER for PRESSURE and FLOW MODEL 555A PART NO. 00555001



**Elkhart Brass Mfg. Co., Inc.**  
www.elkhartbrass.com  
1302 W. Beardsly Ave., Elkhart, IN 46514  
TEL 1-574-295-8330 TOLL FREE 1-800-346-0250

---

# INTRODUCTION

## Overview

The Portable Standpipe Meter is a self-contained, battery operated device designed for high-rise stand pipe operations. It measures pressure and flow rate directly without using charts or doing calculations. Mounted on a flow tube is an indicator module that has two 4-digit LED displays for both pressure and flow. All electronics are self-contained and powered by a rechargeable battery with quick change housing.

All program features are accessed via pushbutton switches on the front of the indicator module.

## Features

- Low and Critical Battery Alerts
- High and Low Flow Warnings
- High Pressure Warning
- Standby Mode to Save Battery Life
- Pressure and Flow Rate Calibration
- Programmable for PSI/kPa/Bar -- GPM/LPM

## Specifications

The Portable Standpipe Meter is self-contained

- Dimensions: 4 1/2" W 12 1/4" H 7" D
- Weight: 5 LBS
- Coupling: 2 1/2" NH Thread
- Power: HiTECH Rechargeable Battery
- Battery Life: 5 Hours Minimum
- Pressure Sensor Range: 0 - 250 PSI Maximum
- Flow Sensor: Paddlewheel Type;  
Acetal (Delrin) with Stainless Steel (316) Shaft  
250 GPM Maximum

---

# GENERAL DESCRIPTION

## Components

The Portable Standpipe Meter for pressure and flow consists of a flow tube with an integral indicator module.

### Flow Tube

The flow tube construction is comprised of two sections, a 45° elbow on the input side and a straight run for measurement on the output side. The measuring zone includes a combination sensor to measure the pressure and flow. The indicator module is located above the sensor.

### Indicator Module

The indicator module is a combination digital pressure and flow meter with programming features that include calibration, high and low warning settings, and units of measure. The control panel has two pushbuttons and two 4-digit LED displays to indicate pressure and flow rate. The displays has 0.28" high digits, bright red for pressure and blue for flow.

All electronics are enclosed in a waterproof aluminum case with a sealed overlay on the controls. It meets NEMA 4X standard for water-tight/dust-tight and has a minimal IP67 rating for protection against penetration of liquids.

A low battery warning goes active a minimum of 90 minutes before the low voltage battery cut-off is reached. A critical battery warning goes active a minimum of 10 minutes before the low voltage cutoff is reached. The low battery warning stays active until the battery is replaced with a fully charged battery.

## Controls and Indicators

All controls and indicators are located on the front of the display module.

### PRESSURE Display

During normal operation this 4-digit, red LED display indicates pressure. It flashes a warning message when pressure exceeds programmed setting.

### BATT Button

The BATT button allows the operator to check the battery.

### ON/OFF Button

The ON/OFF button controls power to the display module.

### FLOW Display

During normal operation this 4-digit, blue LED display indicates flow rate. It flashes warning messages when flow is outside programmed high and low settings.

---

## OPERATION

Connect the meter to a standpipe and make the hose connection. There are three modes of operation:

**ON** - To power up the meter press and hold the ON/OFF button until both displays shows four dashes — — — — . Release the button. The displays show pressure (upper display, red LEDs) and flow (lower display, blue LEDs).

**STANDBY** - When the flow is less than 3 GPM for more than 15 minutes, the meter goes into Standby Mode and cuts power to the displays. It wakes up when the flow rises above 3 GPM for 3 seconds. The meter shuts off if it is in the Standby Mode for more than 30 minutes (this is a programmable function).

**OFF** - To power down the meter press and hold the ON/OFF button for 3 seconds. The pressure display shows OFF for 3 seconds then powers down.

Press the BATT button to check the battery. When LO BATT shows in the display, it indicates that there is 1.5 hours or less of charge left.

## Calibration

The pressure and flow meters are precalibrated and tested at the factory. Flow and pressure codes are available to make adjustments if it is necessary to calibrate the meter.

Refer to the Programming Section for codes and program information.

Connect the meter with a calibrated reference meter in line. Select a pressure or flow rate for calibration that is within the most commonly used range.

**Note:** The pressure calibration has two calibration points, one for the low pressure or zero PSI and a second for the high pressure or applied pressure for calibration.

Bring up the pressure or flow water to set the calibration points.

## Programming

To gain access to the program features a three digit program code must be entered. Refer to Table 1. Program Code Quick Reference for the proper three-digit code.

Both the **BATT** and **ON/OFF** buttons are used to enter program codes and change the settings. The **BATT** button selects the digit to change and the **ON/OFF** button changes the digit.

### Enter Program Code

**Note:** There is a time-out feature that returns the program to normal operation in five seconds if input is not detected.

1. Press and hold the **BATT** and then hold **ON/OFF** buttons (at the same time) until the display shows four dashes – – – – . Release the buttons.
2. Press the **BATT** button to select the digit to be change. The digit flashes. Press the **ON/OFF** button to change the digit.
3. Enter the code from Table 1. Program Code Quick Reference.

Results: The display shows the selected program feature.

4. Set calibration, warning, unit of measure, or standby timer as required.
5. First press and hold the **BATT** button and then press and hold the **ON/OFF** button (holding both buttons at the same time) to exit.

**Table 1. Program Code Quick Reference**

CODE	DESCRIPTION	DEFAULT	NOTES
314	Unit of Measure	g-P	Sets the unit of measure for pressure and flow as follows: g-P = GPM/PSI L-Pa = LPM/kPa L-b = LPM/Bar
315	High Flow Warning	250	Sets the high flow warning. When the flow rate is above setting, the flow display alternately flashes the flow rate and HI-F. Set to 0 to disable.
316	Low Flow Warning	80	Sets the low flow warning. When the flow rate is below the setting, the flow display alternately flashes the flow rate and LO-F. Set to 0 to disable.
321	Flow Calibration	N/A	Starts the calibration program for flow rate.
323	High Pressure Calibration	N/A	Starts the calibration program for high pressure setting.
324	Low Pressure Calibration	N/A	Starts the calibration program for low (zero) pressure setting.
325	High Pressure Warning	200	Sets the high pressure warning. When pressure is above the setting, the pressure display alternately flashes the pressure and HI-P. Set to 0 to disable.
341	Standby Mode Timer	30	Sets the time the meter is in standby before it shuts down.

## Battery Information

A HiTECH Ultra High Capacity rechargeable battery is used to power the portable standpipe meter. Use only the approved batteries and chargers.

The meter is designed for maximum battery life. Always shut the unit **OFF** when not in use. The battery may be checked anytime to see if more than 90 minutes (**BATT GOOD**) of runtime remains, by pressing and holding the **BATT** push button.

### Important notes:

- Do not use a damaged battery or charger; immediately dispose of them properly.
- Please do not leave batteries charging unattended.
- Do not attempt to charge other types of batteries in the approved charger.
- Do not attempt to use other types of chargers with the approved batteries.
- Please read all instructions provided with the charger and batteries carefully.
- Do not attempt to use these batteries in other equipment, as damage to the battery or the device may occur.
- Never short the terminals on the batteries.

Also, please do not attempt to use other types of batteries in the meter. The approved HiTECH battery is designed to provide a large electrical current to operate the meter properly. It contains special circuitry that is not found in other types of batteries.

## Battery Removal/Replacement

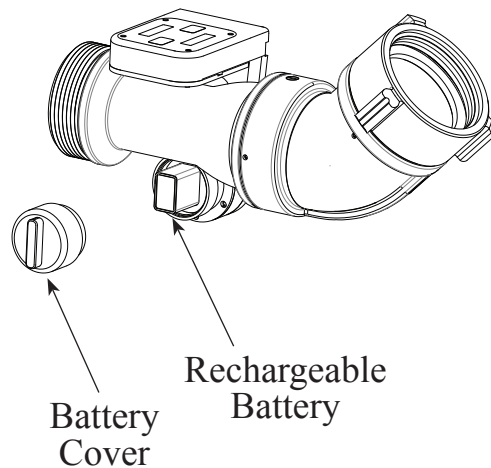

Replace a weak battery with a fully charged HiTECH battery. The battery can be replaced while the unit is being operated. Ensure that fluids do not enter the battery compartment.

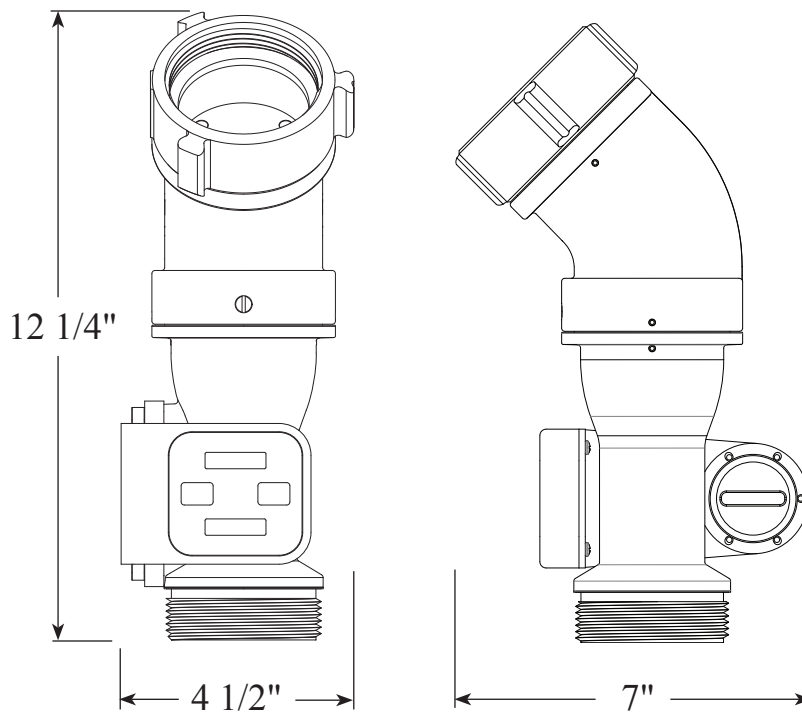

**Figure 1. Dimensions**



### **PERSONAL RESPONSIBILITY CODE**

The member companies of FEMSA that provide emergency response equipment and services want responders to know and understand the following:

1. Firefighting and Emergency Response are inherently dangerous activities requiring proper training in their hazards and the use of extreme caution at all times.
2. It is your responsibility to read and understand any user's instructions, including purpose and limitations, provided with any piece of equipment you may be called upon to use.
3. It is your responsibility to know that you have been properly trained in Firefighting and/or Emergency Response and in the use, precautions, and care of any equipment you may be called upon to use.
4. It is your responsibility to be in proper physical condition and to maintain the personal skill level required to operate any equipment you may be called upon to use.
5. It is your responsibility to know that your equipment is in operable condition and has been maintained in accordance with the manufacturer's instructions.
6. Failure to follow these guidelines may result in death, burns or other severe injury.



Fire and Emergency Manufacturers and Services Association, Inc.  
P.O. Box 147, Lynnfield, MA 01940 [www.FEMSA.org](http://www.FEMSA.org)

Copyright 2006 FEMSA. All Rights Reserved